

# A GUIDE FOR PARISHES AND ORGANIZATIONS

Exhibit Designed by Blessed Carlo Acutis

## *Eucharistic Miracles* OF THE WORLD



1400 NE 42nd Ter.  
Kansas City, Mo. 64116  
816-630-1090  
[catholicradio.com](http://catholicradio.com)



*Vatican International Exhibition*

# EUCCHARISTIC MIRACLES OF THE WORLD

# TABLE OF CONTENTS

What is a Eucharistic Miracle? .....	4
Eucharistic Miracles Included in the 157 Panel Exhibit.....	5-9
Exhibit is Free to View.....	10
Promote Your Exhibition.....	11-12
Additional Marketing Suggestions.....	12-13
Manage the Exhibition/Table Materials.....	13
Pick-Up, Transport and Return of the Exhibit.....	14
Set-Up and Take Down of the Exhibit.....	15-18
Additional Information About the Eucharistic Miracles.....	19
Best Practices: Get Youth Engaged in Your Exhibition Event.....	20
Frequently Asked Questions.....	21
More on Perpetual Adoration.....	22
Attachments.....	23-29

Vatican International Exhibition  
*Eucharistic Miracles of the World*

Guide for Parishes and Organizations

**WHAT IS A EUCHARISTIC MIRACLE?**

Eucharistic miracles consist of unexplainable phenomena occurring after transubstantiation, such as a host visibly transforming into human tissue, a host surviving fire, a host bleeding or the Eucharist alone providing sustenance to a human being for a prolonged period of time. In order to be considered a Eucharistic miracle, the event is investigated by a special task force before deciding it is worthy of belief. Secular sources are often used to investigate and confirm the miracle. Belief in approved miracles is not mandated by the Catholic Church, but can reassure believers of God's presence in our world.

*"Now as they were eating, Jesus took bread, and blessed, and broke it, and gave it to the disciples and said, 'Take, eat; this is my body.' And he took a cup, and when he had given thanks he gave it to them, saying, 'Drink of it, all of you; for this is my blood of the covenant, which is poured out for many for the forgiveness of sins.'"*



**ABOUT THE EXHIBIT**

Catholic Radio Network is proud to be the home of two sets of the powerful *Eucharistic Miracles of the World* exhibit. We've made the exhibit available to the public by loaning it to parishes and organizations at no cost.

This Vatican-approved international exhibit was designed and created by Blessed Carlo Acutis. Carlo, an artist, cartoonist and avid computer enthusiast, created the art for the panels before his death from leukemia at age 15. His goal during his short life was to help bring others closer to Jesus through awareness of the mystery of the Eucharist. Carlo received the sacrament of the Eucharist daily and desired to share the joy of Christ's presence with the world through his God-given talents. The exhibit is presented in the United States by the Real Presence Eucharistic Education and Adoration Society.

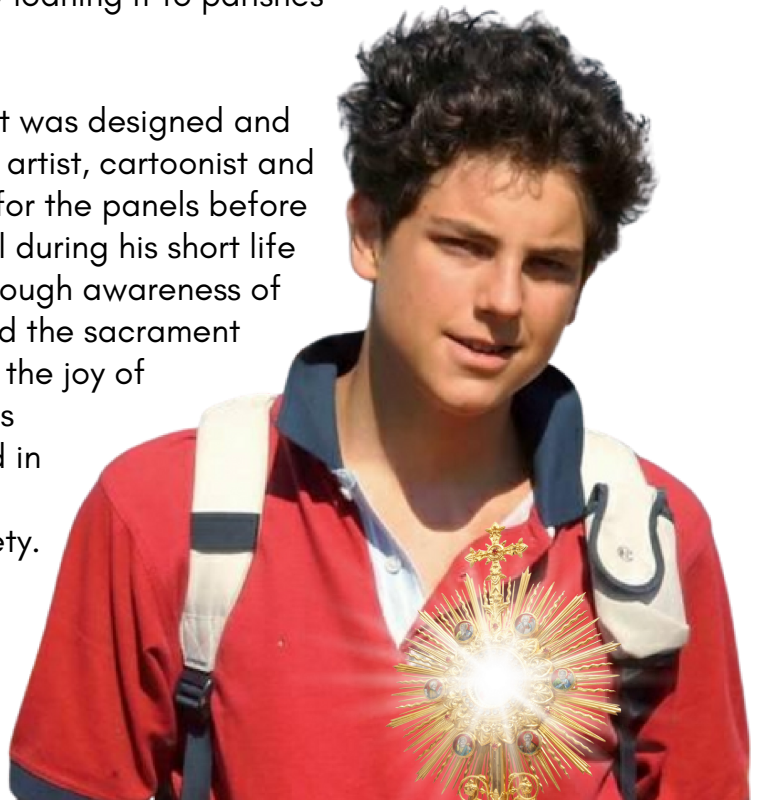

## ***EUCCHARISTIC MIRACLES INCLUDED IN THE 157 PANEL EXHIBIT***

The following is a list of the Eucharistic Miracles of the World panels that are part of the Catholic Radio Network traveling exhibit.



***Posters arranged alphabetically by country and then chronologically within each county.***

*(String 1 for **Row 1** in Box 1 - 10 panels, 20 posters)*

### ***FRONT***

Miraculous Communion Part 1  
Miraculous Communion Part 2  
IV Century St Satyrus  
1224 - 1274 St Thomas Aquinas  
1550 - 1568 St Stanislaus Kostka  
1638 - 1686 Bl. Nicholas Steno (Steensen)  
XX Century Andre Frossard  
Argentina 1992 Buenos Aires #1  
Argentina 1994 Buenos Aires #2  
Argentina 1996 Buenos Aires #3

### ***BACK***

Germany 1330 Walldurn  
Germany 1280 Kranenburg  
Germany 1255 Regensburg  
Germany 1216 Benningen  
Germany 1194 Augsburg  
Germany 1125 Bettbrunn  
Germany 1898-1962 Theresa Neumann  
Germany 1774-1824 Blessed Ann Emmerich  
Germany Weingarten #2  
Germany Weingarten #1

(String 2 for **Row 1** in Box 1 - 12 panels, 24 posters)

**FRONT**

Austria	1310	Fiecht
Austria	1384	Seefeld
Austria	1411	Weiten-Raxendorf
Belgium	1203	Bruges
Belgium	1317	Herkenrode-Hasselt
Belgium	1370	Brussels
Belgium	1374	Middleburg-Lovanio
Belgium	1374	Liege (Corpus Christi)
Belgium	1405	Bois-Seigneur-Isaac
Belgium	1412	Herentals
Caribbean	1902	Morne-Rouge
Columbia	1906	Tumaco

**BACK**

France	1888	Lourdes
France	1822	Bordeaux
France	1668	Les Ulmes
France	1643	Pressac
France	1608	Faverney
France	1589	Pibrac - St Germaine Cousin
France	1533	Marseille-En-Beauvais
France	1461	La Rochelle & Neuvy Saint Sepulcre
France	1433	Avignon #2
France	1433	Avignon #1
France	1430	Dijon
France	1331	Blanot

(String 3 for **Row 1** in Box 1 - 6 panels, 12 posters)

**FRONT**

Croatia	1411	Ludbreg #1
Croatia	1411	Ludbreg #2
Egypt	IV-V cent	St. Mary of Egypt
Egypt	III-IV cent	Scete
France	XVII cent	St Margaret Mary
France	1902-1981	Alacoque-Sacred Ht Servant Marthe Robin

**BACK**

France	1290	Paris #2
France	1290	Paris #1
France	1254	Douai
France		St Egidio (St Gilles)
France	1830	St Catherine Laboure
France	XII cent	St Bernard & St John Bosco Chiar. Italy 1848



*Eucharistic Miracles*

(String 4 for **Row 2** in Box 2 - 10 panels, 20 posters)

**FRONT**

Germany	1383	Wilsnack
Germany 1417	India	Erding
2001	La	Chirattakoman
Reunion1902	Italy	St Andre de la Reunion
1347-1380	Italy	St Catherine of Siena
1240 ItalyXIII	cent	St Clare
ItalyXI cent	Italy	St Francis of Assisi
1230-1595	ItalyVI-	St Peter Damian & Scala
VII cent		Florence <sup>(1732)</sup>
		Rome VI-VII Century #1

**BACK**

Peru	1649	Eten
Netherlands	1572	Gorkum-El-Escorial
Holland	1429	Alkmaar
Holland	1421	Bergen
Holland	1400	Boxmeer
Holland	1380	Boxtel-Hoogstraten
Holland	1345	Amsterdam #2
Holland	1345	Amsterdam #1
Holland	1342	Stiphout
Holland	1300	Breda-Niervaart

(String 5 for **Row 2** in Box 2 - 12 panels, 24 posters)

**FRONT**

ItalyVI-VII	cent	Rome VI-VII Century #2
Italy 750	Italy	Lanciano #1
750 ItalyXI	cent	Lanciano #2
Italy 1171	Italy	Trani
1227 Italy	1228	Ferrara
Italy 1264	Italy	Rimini
1264 Italy	1273-	Alatri
1280 Italy	1294	Bolsena #1
Italy 1330		Bolsena #2
		Offida
		Gruaro (Valvasone)
		Cascia

**BACK**

Holland	1222-1465	Meerssen
Mexico	2006	Tixtla #2
Mexico	2006	Tixtla #1
Mexico	1531	Guadalupe
Italy	1948 1866-	Rosano
Italy	1912 1772	Bl. Mary of Passion
Italy	1730	Patierno (Naples)
Italy	1718	Siena
Italy	1656	Asti #2
Italy	1640	Cava dei Tirreni
Italy	1631	Turin #3
Italy		Dronero & St Mauro La Bruca

(String 6 for **Row 2** in Box 2 - 6 panels, 12 posters)

**FRONT**

Italy	1356	Macerata
Italy	1412	Bagno di Romagna
Italy	1453	Turin #1
Italy	1453	Turin #2
Italy	1472	Volterra
Italy	1517	Salzano

**BACK**

Italy	1630	Canosio
Italy	1610	Rome #3
Italy	1604	Mogoro
Italy	1570	Veroli
Italy	1560	Morrovalle
Italy	1535	Asti #1

(String 7 for **Row 3** in Box 3 - 10 panels, 20 posters)

**FRONT**

Poland	XX cent	St Faustina Kowalska
Poland	1290	Glotowo
Poland	1345	Krakow
Poland	1399	Poznan
Poland	2008	Sokolka #1
Poland	2008	Sokolka #2
Poland	2008	Sokolka #3
Poland	2013	Legnica #1
Poland	2013	Legnica #2
Portugal	1904-1955	Bl. Alexandrina Maria de Costa

**BACK**

Venezuela	1991	Betania
Switzerland	1447	Ettiswil #2
Switzerland	1447	Ettiswil #1
Spain	1907	Silla
Spain	1824	Onil #2
Spain	1824	Onil #1
Spain	1657	Montserrat
Spain	1640	Calanda
Spain	1597	Alcala
Spain	1568	Alcoy



*Eucharistic Miracles*



(String 8 for **Row 3** in Box 3 - 11 panels, 22 posters)

**FRONT**

Portugal	1916	Angel of Peace #1
Portugal	1916	Angel of Peace #2
Portugal	1916	Angel of Peace #3
Portugal	1247	Santarem #1
Portugal	1247	Santarem #2
Spain	1251	St John of the Abbesses
Spain		Valencia #1
Spain		Valencia #2
Spain	1010	Ivorra #1
Spain	1010	Ivorra #2
Spain	1231	Caravaca de la Cruz

**BACK**

Spain	1533	Ponferrada
Spain	1427	Zaragoza
Spain	1420	Guadalupe Spain
Spain	1392	Moncada
Spain	1370	Cimballa
Spain	1348	Alboraya-Almacera #2
Spain	1348	Alboraya-Almacera #1
Spain	1300	O'Cebreiro
Spain	1297	Gerona
Spain	1239	Daroca #2
Spain	1239	Daroca #1

Three single posters in box 3: Monstrance, Carlo Acutis, Miracles  
(77) Double sided panels, (3) Single sided panels, (157) Posters



*Eucharistic Miracles*

## *EXHIBIT IS FREE TO VIEW*

Because Catholic Radio Network provides the Eucharistic Miracles of the World exhibit at no cost to parishes and organizations, there must never be an admission fee or tickets sold for people to see the exhibit. However, Catholic Radio Network provides a locked donation box to accept free-will offerings. We ask you to place this donation box on a small display table near the exhibit. Funds collected are used for the upkeep of the exhibit and for print materials. All donations above expenses are provided to the Real Presence Eucharistic Education and Adoration Association, the non-profit organization who generously allows Catholic Radio Network to present the exhibit.

## ***PROMOTE YOUR EXHIBIT***

Upon agreeing to host the Eucharistic Miracles of the World exhibit, you may consider promoting your exhibition event with the following suggestions.

### ***Bulletin and/or Pulpit Announcements***

Provided below is a template (to be customized with your specific exhibition event location, display dates and viewing times) for inclusion into your parish bulletin and/or for use as a pulpit or intercom announcement. Feel free to also share this bulletin announcement with your neighboring parishes and encourage them to come and see the Eucharistic Miracles as well.

### ***Eucharistic Miracles of the World Coming to Parish Name***

(Parish Name) will be hosting the Vatican-approved international Eucharistic Miracles of the World exhibit from Insert Display To-From Dates in the Parish Hall at Street Address, City Name. It is free to view from Time a.m. to Time p.m. on Day(s) of Week. The Eucharistic Miracles of the World exhibit is a traveling display on loan from Catholic Radio Network. It features 157 beautiful panels that highlight some of the most powerful Eucharistic miracles in the world. For more information, visit [catholicradio.com/miracles](http://catholicradio.com/miracles).

### ***8 ½ x 11 Flyer***

Once your event is booked and confirmed, Catholic Radio Network will provide you with an an 8 ½ x 11 flyer (to be customized with your specific exhibition event location, display dates and viewing times). This flyer may be used for handouts and/or posting on your bulletin boards, or for use to insert into the bulletin as a separate sheet, or to attach in an email to invite parishioners, organizational members, Catholic schools and parents, or others to your event. (The flyer can be found on the last page of this guide)

### ***Free Online Events Calendar***

Catholic Radio Network has a free online events calendar that receives views on a regular basis. We encourage parishes and organizations to post their exhibition event of the Eucharistic Miracles at <https://catholicradio.com/events/>. It may take up to five business days for an event to appear in the online events calendar at <https://catholicradio.com/events/>.

## ***Additional Marketing Suggestions***

### ***Diocesan Information***

#### **Archdiocese of Kansas City in Kansas**

<https://archkck.org/>

#### **Diocese of Kansas City-St. Joseph - *Monday Minute* -**

[https://m.facebook.com/DioceseKCSJ/posts/10161155634505579/?\\_se\\_imp=0g0iJMOHrgnLS3a1j](https://m.facebook.com/DioceseKCSJ/posts/10161155634505579/?_se_imp=0g0iJMOHrgnLS3a1j)

#### **Archdiocese of Denver** <https://archden.org/>

#### **Diocese of Colorado Springs** <https://www.diocs.org/>

#### **Diocese of Pueblo** <https://www.diopueblo.org/>

#### **Diocese of Wichita** <https://catholicdioceseofwichita.org/>

#### **Diocese of Springfield - Cape Girardeau** <https://dioscg.org/>

### ***Diocesan Newspapers:***

#### **Archdiocese of Kansas City in Kansas Newspaper - *The Leaven***

<https://theleaven.org/> Submit to: [beth.blankenship@theleaven.org](mailto:beth.blankenship@theleaven.org). DEADLINE: Noon, Thursday, eight days before the desired publication date.

#### **Diocese of Kansas City-St. Joseph Newspaper - *The Catholic Key***

<https://catholickey.org/>

#### **Archdiocese of Denver Newspaper - *The Denver Catholic***

<https://denvercatholic.org/>

#### **Diocese of Colorado Springs Newspaper - *The Colorado Catholic Herald***

<https://www.diocs.org/Herald>

#### **Diocese of Pueblo Communications**

<https://www.diopueblo.org/communications>

#### **Diocese of Wichita Newspaper - *The Catholic Advance***

<https://catholicdioceseofwichita.org/news/>

#### **Diocese of Springfield Newspaper - *The Mirror***

<https://dioscg.org/articles-and-columns/the-mirror/>

- Feel free to also consider promoting your event through secular media sources such as your local newspapers, secular radio stations, and various social media websites.
- With advance permission, you may also post your event flyers at neighboring parishes, in local grocery and retail stores, restaurants, gas stations and truck stops.

## MANAGE YOUR EXHIBIT

It is a good idea to be mindful of where and how you set up the Eucharistic Miracles of the World exhibit. You will need a reasonable amount of space for the exhibit, and you will also need a small table for display-related materials.

Many parishes set up the exhibit either in their church hall, narthex or school gym. When setting up the exhibit, remember to place the panels in proper sequential order by date of when the miracles occurred. See page 5 of this Guide for more details as well as a properly-ordered list of the miracles.

### ***Set Up a Small Display Table Near the Exhibit***

You will need a small display table (4'x4' or a 6'x 6' table is a good size) for the free materials and items listed below that are provided by Catholic Radio Network as part of the exhibit. We suggest you cover the table with a nice-looking table cloth and place the table near the entrance of the exhibit.

### **CATHOLIC RADIO NETWORK PROVIDES SOME HELPFUL HANDOUTS AS PART OF THE EXHIBIT**

***Eucharistic Miracles of the World Rack Cards*** - These handy cards explain the origination of the exhibit and its creator, Bl. Carlo Acutis, as well as other helpful information.

***Catholic Radio Network Program Grids*** - This 8 ½ x 11 flyer illustrates a program grid listing all programs heard on-air, Monday-Friday as well as weekend programming for Saturday and Sunday.

***Common Questions About Perpetual Adoration Handout*** - Once your event is booked and confirmed, this 8 ½ x 11 handout will be emailed to you for optional use at your exhibition event. You may choose to make photocopies and include it as a handout during your exhibit. It provides answers to why Perpetual Adoration is important and how it is helpful in increasing our faith in Jesus.

***Free-Will Offering Box*** - Catholic Radio Network also provides a locked donation box to accept free-will offerings. We ask you to place this donation box on a small display table near the exhibit. Funds collected are used for the upkeep of the exhibit and for print materials. All donations above expenses are provided to the Real Presence Eucharistic Education and Adoration Association, the non-profit organization who generously allows Catholic Radio Radio to present the exhibit.

### ***Exhibition Viewing Signage***

Once your event is booked and confirmed, Catholic Radio Network will provide you with a Word document of 8 ½ x 11 editable signs that you can customize, print and post in your exhibit area to help visitors know where to start viewing the exhibit and which direction to proceed as they view each of the Eucharistic Miracles. See Attachment C for an example of what these signs look like.



## PICK-UP, TRANSPORT AND RETURN OF THE EXHIBIT

The parish or organization hosting the exhibit is responsible for both picking it up from and returning it to the Catholic Radio Network studios. Our location is 1400 NE 42nd Terrace in Kansas City, Missouri. The exhibit contains three handled boxes (30 x 22 x 7) that will fit in the back seat or trunk of most regular-sized vehicles.

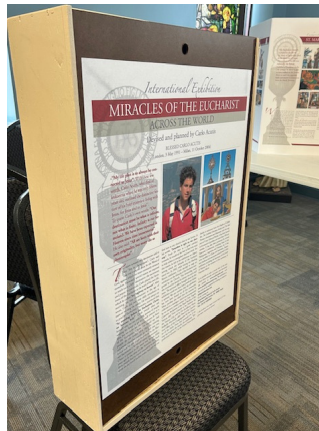

### **Sign the "Acceptance of Stewardship, Care & Responsibility" Form at Pick-Up**

When you arrive at the appropriate Catholic Radio Network location to pick-up the reserved exhibit for your parish or organization, you will be required to read, acknowledge and sign the "Acceptance of Stewardship, Care & Responsibility" form before the exhibit can be released and entrusted to your care. It is expected and appreciated that you take proper care of the exhibit, as well as repack it and return it in the same manner AND condition as it was received.

**PLEASE DO NOT ALLOW YOUTH UNDER AGE 15 TO HANDLE, SET-UP OR TAKE DOWN THE EXHIBIT.**

See **Attachment D** for a copy of the "Acceptance of Stewardship, Care & Responsibility" form.

### **Complete the "Proper Care, Packing & Return Checklist" Form Before Returning Exhibit**

When you return the exhibit to the same Catholic Radio Network location where you picked it up at, you will be required to provide us with your completed and signed "Proper Care, Packing & Return Checklist" form to ensure the exhibit is properly repacked in an acceptable manner and returned in good condition. We will ask you, before you leave the Catholic Radio Network station, to take time to review this form with us, together, so we can inspect the exhibit and the manner in which it was repacked and returned. Please kindly let us know immediately if any stands, exhibit panels, pieces or parts are broken, damaged or missing.

See **Attachment E** for a copy of the "Proper Care, Packing & Return Checklist" form.

## *SET-UP AND TAKE DOWN OF THE 157 PANEL EXHIBIT*

The 157 panel exhibit is to be set up on 17 6 foot tables. You will need an additional table for the Catholic Radio Network table materials. This is a total of 18 tables. Two beautiful vinyl panels (plus their stands) will accompany this display. Set them near the exhibit in a highly visible area. You may set these next to the entrance into the room where the display will be held, next to the beginning of the display, or next to the materials table. The panels give a little bit of information on the display, so they are a good way to get people's attention and draw them into the exhibit.



### **1.** Handle with care!

- Wear gloves.
- Foam Core Panels are easily damaged – do not drop on corners or edges!
- Ink is water based. Water drops can smear the ink.
- Glue is sensitive to temperature variations –keep at room temperature.
- Do not separate panels that are hinged together.
- Do not apply tape to any part of the display or storage boxes.

### **2.** Slide lid off box. Overturn box carefully to drop posters on table.

### **3.** This exhibit is designed to be displayed on 3 long rows of tables (36' long each).

**4.** The strings of posters are arranged alphabetically by country and chronologically within each country. The recommended route allows viewing in this order.

**5.** Table cloths, appropriate music, flowers and/ or candles are recommended.

**6.** A glue stick is provided for minor repair of poster corner separating from panel. Contact the printer for major repairs or replacements.

**7.** Please return the posters in the order removed from the storage boxes.



NO FOOD OR DRINKS

↑ Lift box  
up away  
from posters.

**INK CAN SMEAR!**  
Avoid rubbing panels  
together when removing  
or inserting into boxes.

Slide open lid.  
Overturn box to drop  
posters on table.

Corners are **FRAGILE!**  
Do not crush corners.

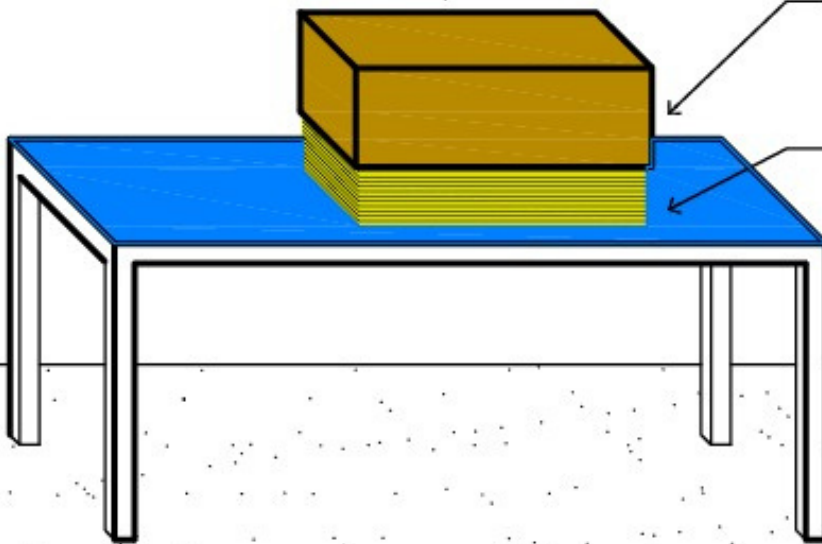



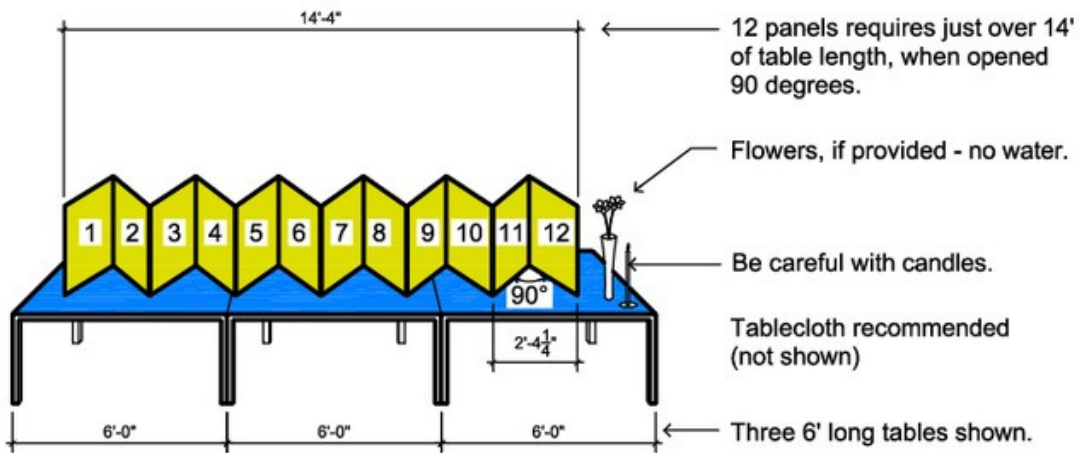

***Posters arranged alphabetically by country and then chronologically within each country.***

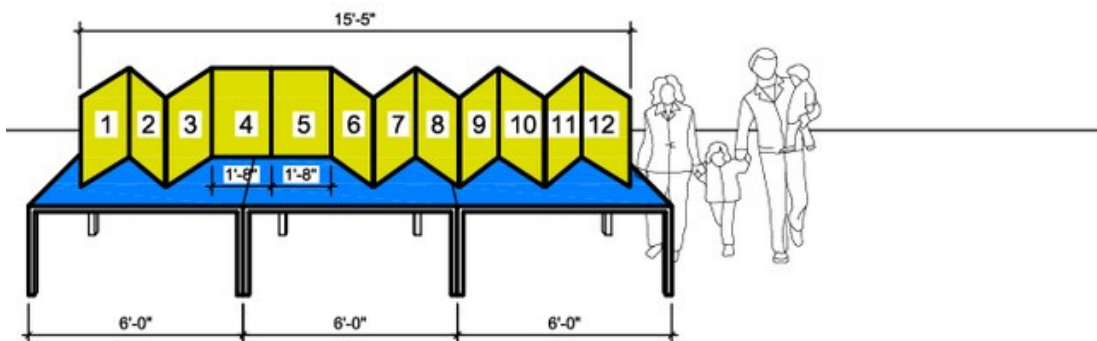

Two or Three related panels may be featured

# FLOOR PLAN ALPHABETICAL & CHRONOLOGICAL

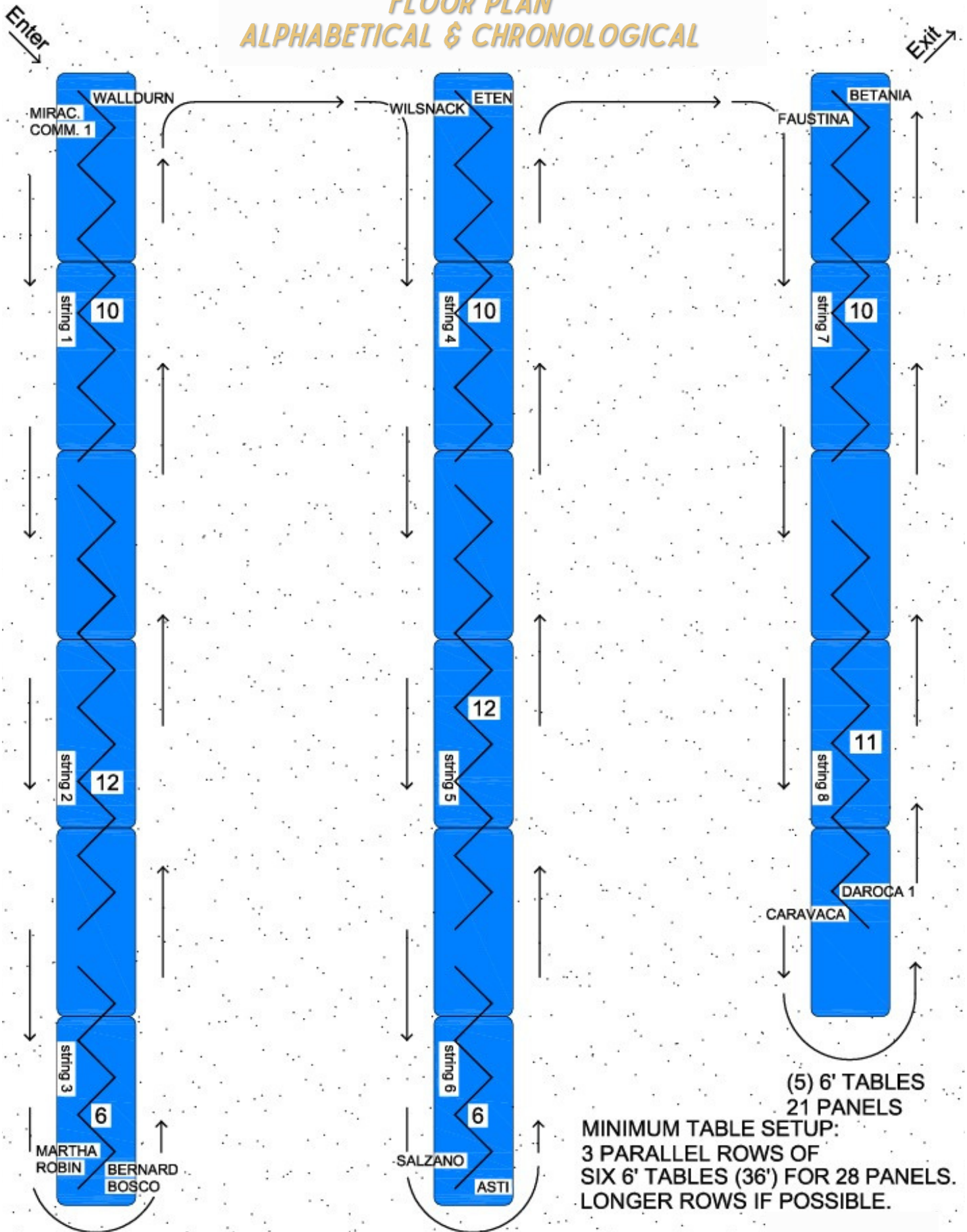

## ADDITIONAL INFORMATION ABOUT THE EUCHARISTIC MIRACLES

Provided below are some helpful resources where you can access additional information about the Eucharistic Miracles of the World.

### **Book of The Eucharistic Miracles of the World**

This book is available on Amazon.com and local Catholic book stores:

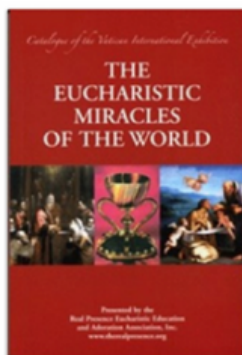

**Paperback:** 330 pages  
**Publisher:** Eternal Life; 1st edition (2009)  
**Language:** English  
**ISBN-10:** 1931101027  
**ISBN-13:** 978-1931101028  
**Package Dimensions:** 8.9 x 6 x 1 inches  
**Shipping Weight:** 1.4 pounds  
**Average Customer Review:** ★★★★★

**Real Presence Website** - [http://www.therealpresence.org/eucharst/mir/engl\\_mir.htm](http://www.therealpresence.org/eucharst/mir/engl_mir.htm)

Here you will find "Relevant Articles about the Eucharistic Miracles" and a PDF for each miracle listed by country. You will also find a wonderful Children's Eucharist Video, "The Eucharist, My Highway to Heaven" with three young boys talking about the Eucharist. For this video, you are encouraged to download the MP4 file:

[http://www.therealpresence.org/eucharst/mir/the\\_eucharist\\_1920x1080.mp4](http://www.therealpresence.org/eucharst/mir/the_eucharist_1920x1080.mp4)  
(Right click the link and choose "Save link as")

This 49-minute video may be shown to children at your Eucharistic Miracles exhibition or at any other appropriate Church event. The video was put together by Antonia Salzano Acutis, and as such, the copyright © 2016 rightfully belongs to her. (Please note that the file for downloading has a full resolution of 1920 x 1080p, and is 845 Mbytes).

**Italy Website** - <http://www.miracolieucaaristici.org/>

On this website, they have a page where you can search and download each miracle individually, or you can choose to download a full PDF of ALL the miracles and print them, along with some editable leaflets and brochures here:

<http://www.miracolieucaaristici.org/en/Liste/download.html>

As in #2 above, this website also has the same video, "The Eucharist, My Highway to Heaven" with easy access to view it directly from their webpage or you can also download it: <http://www.miracolieucaaristici.org/en/Video/video.html>

**Carlo Acutis Website** - <http://www.carloacutis.com/en/association/mostra-miracolieucaaristici>

Here you will find out more about Bl. Carlo Acutis, his background, and the cause for his beatification. If you email them at [info@carloacutis.com](mailto:info@carloacutis.com) or complete their online form, they will send you some interesting materials and brochures, free of charge and in English, directly from Italy.

## *BEST PRACTICES: GET YOUTH ENGAGED IN YOUR EXHIBITION EVENT*

Our Lady of the Holy Rosary Church in Glenwood, Iowa, displayed the Eucharistic Miracles of the World exhibit to celebrate 20 years of adoration. During this celebration, they were also intent on engaging their youth in learning about the Real Presence of Jesus in the Holy Eucharist. Guided by the Holy Spirit, the co-teachers of the Senior CCD Class, Monica Hughes, Mary Sneed, and Deb DeYoung were inspired with an incredible plan.

First, about two weeks before the scheduled exhibition event, the teachers discussed with the class what a Eucharistic Miracle is (see page 5). Then they assigned each senior student a Eucharistic Miracle to research (see page 7 for a complete list of each Eucharistic Miracle included in Spirit Catholic Radio's traveling exhibit). During the CCD class, each student was asked to pull out their cell phone, search for their assigned miracle on the Real Presence Website (see page 17), and study the interesting facts and findings about "their" miracle.

Next, on a Wednesday evening from 6:30 p.m. to 8:00 p.m., the CCD classes viewed the Eucharistic Miracles exhibit together in groups, with phased-in start times arranged by grade level. The Senior CCD Class led the instruction of over 150, 3rd through 11th graders about the Eucharistic Miracles. Each senior stood by their assigned miracle's panel, and as the youth rotated through the exhibit to view and learn about each miracle, it was the responsibility of each senior to teach and discuss the miracles with the youth.



"The seniors, as well as the younger students, all learned about the Real Presence of Jesus in the Blessed Sacrament. The lives of the youth were forever changed by the amazing holy instruction offered by the seniors regarding the significance of the Holy Eucharist. All the kids were astonished to learn about Eucharistic Miracles dating from 750 AD to 2008 from all over the world. Many commented they would someday like to visit, in person, the places where these miracles actually occurred."

-Mrs. Monica Hughes, Senior CCD Co-Teacher, Our Lady of the Holy Rosary Church, Glenwood, Iowa

## **FREQUENTLY ASKED QUESTIONS**

### ***How big is the exhibit?***

The 157 table exhibit is to be set up on 17 6' tables. See photos in this Guide on pages 16-18 for more details.

### ***How many days can I reserve the exhibit?***

Your parish or organization may reserve the exhibit from 1-10 days and may pick it up from Catholic Radio Network the day before or day of your event. We request you return the exhibit either the day your event ends or the day after your event ends.

### ***Which Eucharistic Miracles are included in the exhibit?***

See pages 5-9 in this Guide for a complete list of the Eucharistic Miracles of the World that are a part of Catholic Radio Network's traveling exhibits.

### ***Can we receive info sheets or PDFs about each of the Eucharistic Miracles to use for youth or adult education as part of our exhibit event?***

See page 19 of this Guide for additional information about the Eucharistic Miracles of the World where you will find helpful resources and websites that provide downloads of each of the miracles, along with informative articles and a video for children called "The Eucharist, My Highway to Heaven."

### ***Can our exhibition event be promoted on Catholic Radio Network's online Events Calendar?***

Absolutely! It is your option to complete the online entry form on Catholic Network's website to advertise, for free, the Eucharistic Miracles of the World exhibition event at your parish or organization. See page 11 of this Guide to learn how to easily post your event on our calendar.

### ***Will you send me a promotional flyer?***

Yes, we will email you a Word template of an editable 8 ½ x 11 flyer (to be customized with your specific exhibition event location, display dates and viewing times).

### ***Will you send me a bulletin announcement and a pulpit announcement?***

Yes, see page 11 of this Guide for an editable, customizable paragraph for direct inclusion into your bulletin or for use as a pulpit announcement.

### ***How big of a car do I need to transport the exhibit?***

The exhibit comes three boxes. The boxes measure 22 x 30 x 7. See photos on page 14.

### ***Where do I pick up and return the exhibit (where is Catholic Radio Network located)?***

Kansas City area, you will need to pickup and drop-off the display at our Kansas City radio studio located at 1400 NE 42nd Terrace, Kansas City, Missouri 64116.



# Perpetual Adoration

## ***What is Perpetual Eucharistic Adoration?***

Perpetual Eucharistic Adoration is when a parish sets aside a little room, or chapel, that is open seven days a week, 24 hours a day with permanent exposition of Jesus in the Most Blessed Sacrament.

## ***Why is Perpetual Eucharistic Adoration necessary?***

The more we limit the hours of Adoration, the more we limit the availability of Christ to His people. The more we expand the hours, the more we extend the opportunity to adorers. When a chapel is open all the time, then everyone in the parish can participate. Through Perpetual Adoration with exposition we proclaim to our parish and community that Jesus is here, truly present among us today. Pope John Paul II said, "Your faith will help you to realize that it is Jesus Himself who is present in the Blessed Sacrament, waiting for you and calling you to spend one special specific hour with Him each week."

## ***Why is Exposition Necessary?***

The difference between spending time with Jesus in the Blessed Sacrament exposed in a monstrance, rather than in the tabernacle, is the same as the difference between conversing with a friend face to face instead of having a closed door between you. Most adorers say that seeing Jesus under the appearance of the Sacred Host is much more conducive to intimacy than Him being hidden in a tabernacle. It helps adorers to be faithful to their scheduled hours, because they know that Jesus cannot be left alone in the Blessed Sacrament exposed in a monstrance. The scheduled adorers are guardians of the Blessed Sacrament, so their presence is necessary. Yet, the most compelling reason for exposition is because the Holy Spirit asks for it. During his Eucharistic discourse, Jesus made this unmistakably clear:

"Indeed, this is the will of My Heavenly Father, that everyone who looks upon the Son and believes in Him, shall have eternal life. Him I will raise up on the last day." John 6:40

## ***What are the benefits?***

Each person that spends time in the presence of Jesus in the Most Blessed Sacrament grows in holiness. Communally, increased Mass attendance, conversions, the return of the fallen away Catholics and vocations to the priesthood and religious life are among the many fruits of Perpetual Eucharistic Adoration. Through our Holy Hours of prayer, Our Holy Father declared that we are contributing to "the radical transformation of the world," the "establishing of everlasting peace," and the coming of Christ's Kingdom on earth.



*Vatican International Exhibition*  
EUCCHARISTIC MIRACLES  
OF THE WORLD

START  
VIEWING  
EXHIBIT  
HERE

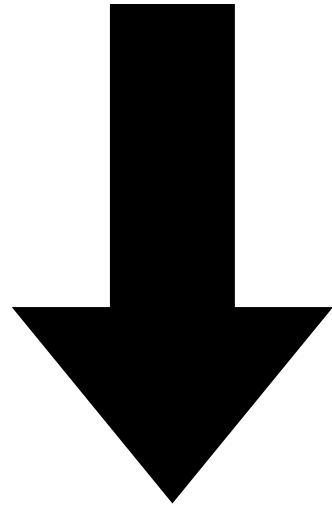

CATHOLIC RADIO NETWORK®



*Vatican International Exhibition*  
**EUCHARISTIC MIRACLES  
OF THE WORLD**

**PROCEED  
TO  
VIEWING  
EXHIBIT  
TO THE  
RIGHT**

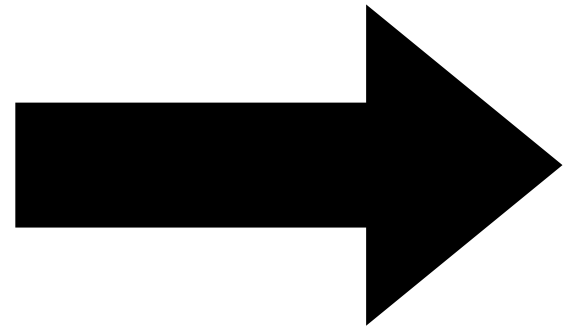

**CATHOLIC RADIO NETWORK®**





*Vatican International Exhibition*  
**EUCHARISTIC MIRACLES  
OF THE WORLD**

**PROCEED  
TO  
VIEWING  
EXHIBIT  
TO THE  
LEFT**

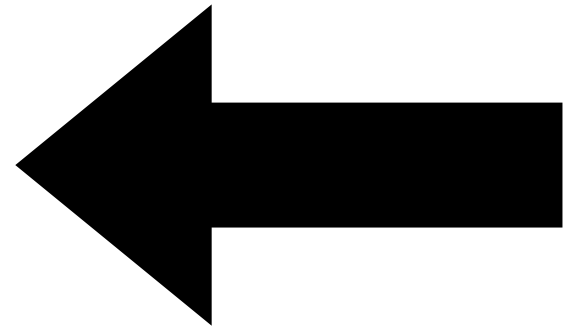

**CATHOLIC RADIO NETWORK®**



*Vatican International Exhibition*  
**EUCHARISTIC MIRACLES  
OF THE WORLD**

**EXHIBIT  
ENDS  
HERE**

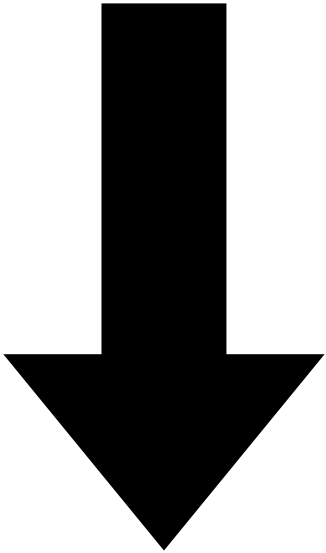

**CATHOLIC RADIO NETWORK®**



*Vatican International Exhibition*  
**EUCHARISTIC MIRACLES  
OF THE WORLD**

**SEE  
EXHIBIT  
IN THE  
PARISH  
NARTHEX**



**CATHOLIC RADIO NETWORK®**



*Vatican International Exhibition*  
**EUCCHARISTIC MIRACLES  
OF THE WORLD**

**SEE  
EXHIBIT  
IN THE  
PARISH  
HALL**



**CATHOLIC RADIO NETWORK®**

# *Eucharistic Miracles* OF THE WORLD



Exhibit Designed by Blessed Carlo Acutis

This area can be customized with your  
parish/organization info and dates

*This Eucharistic display presented by...*



*"Change your station...  
Change your life!"*

CATHOLICRADIO.COM